

Changing Roll Diameters and Web Edge Detection on Unwind and Rewind Guides

Blog Post

Terminal web guides: The roll on my rewind stand changes diameter as it is fed from the converting line, does this affect the detection of the web on my rewind web guide?

Questions that our customers ask.

A customer approached us because he was having trouble with the detection of the web by their **terminal web guide on their rewind stand.**

As the material was fed from the converting line into the rewind stand, the diameter of the roll would increase and the distance from the web to the face of the sensor would decrease. This would cause issues with the effectiveness of the sensor.

The main problem is that the web is experiencing a plane change.

In order for any sensor to work properly, the web has to be stable. That is, the web must maintain the same plane throughout the entire run. When a plane change happens, the sensor will need to be repositioned or calibrated to account for the change in plane.

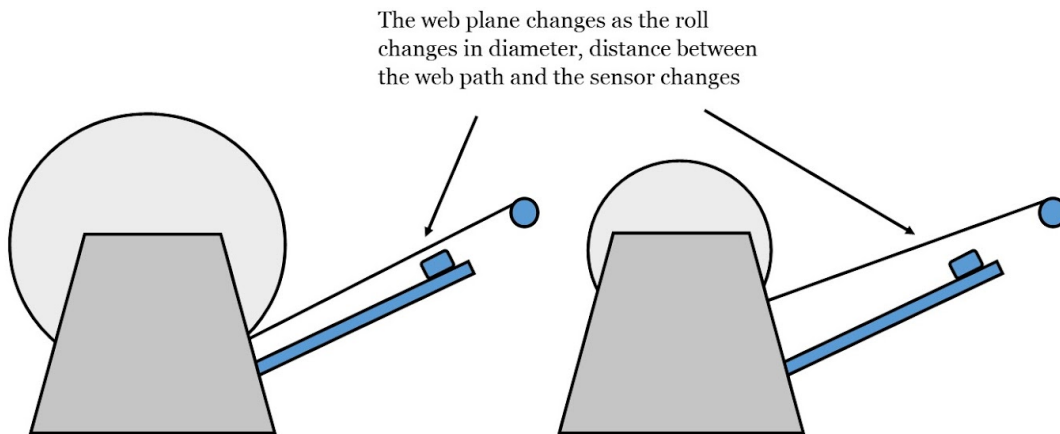

So, in the case of a rewind or unwind stand, as the roll changes the diameter, the web is also changing the plane by increasing or decreasing the distance between the face of the sensor and the web.

This is an easy fix.

All it requires is a fixed idler roller installed on the machine frame for the rewind or on the shifting stand frame of the unwind. In both cases, the sensor would need to be installed after the idler roller on an unwind stand or before the idler roller on a rewind stand. Keep in mind that the idler roller on the rewind stand is fixed to the machine frame and the sensor is attached to the moving rewind stand. With the unwind stand, the idler roller is attached to the shifting stand of the unwind, while the sensor is fixed to the machine frame. As you can see in the diagrams below, the idler rollers help maintain the plane of the web with respect to the sensor face without regard to the diameter change of the unwind or rewind.

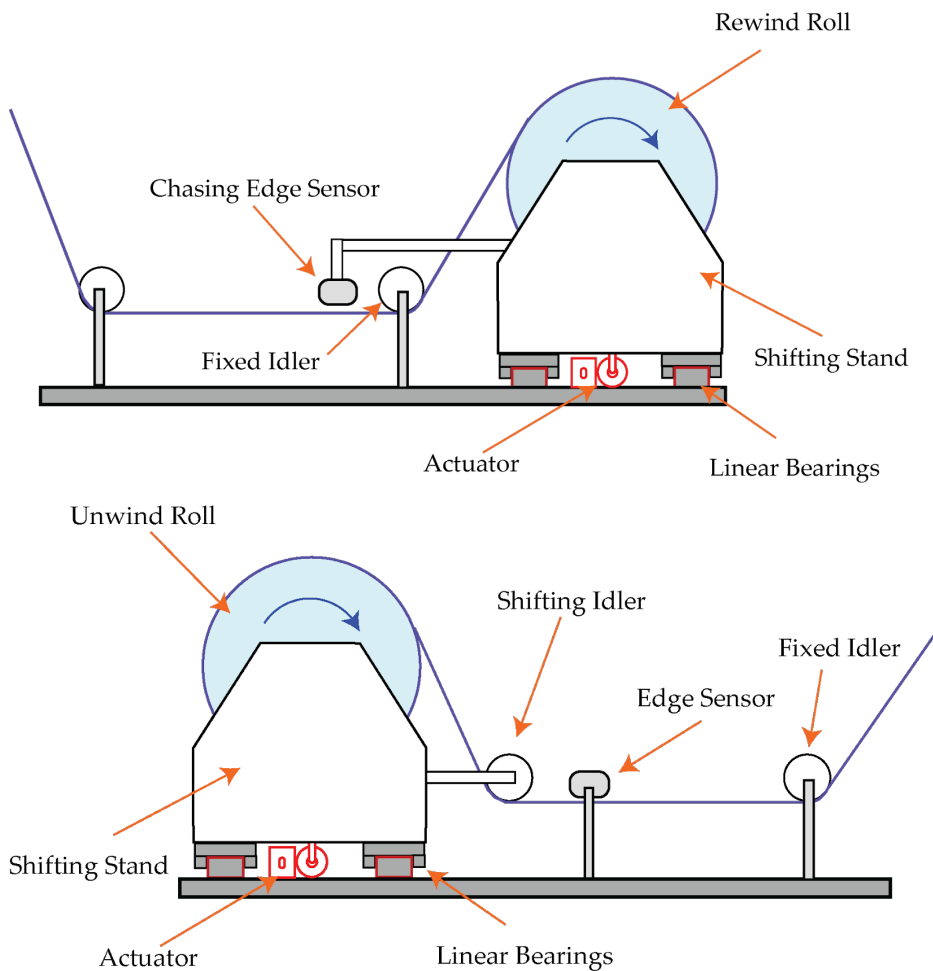

Most unwind and rewinds will come with this idler roller. However, machine builders or integrators that are building their first unwind or rewind, might overlook this requirement and build a unwind or rewind that does not include the idler roller.

Another case could be a converter that is adding a web guide system to an unwind or rewind that was not originally fitted with one. Lack of experience with the fundamentals of web guiding, specifically in terminal web guides, might have them overlook the need for idler rollers in the design. This can also happen when converters are upgrading a current web guiding system that might require changing sensors, controllers and actuators. In this case, the problem might be installing the sensor in the wrong location.

In all three cases, the web will experience plane changes and the sensor will be ineffective in guiding the web as the roll changes diameter.

Having an idler roller that eliminates the effect of the changing roll diameter and properly positioning the sensor with respect to the idler roller is the solution to this problem.

If you liked the information in this blog post, [sign up](#) to receive more information directly from us through our regular newsletter.